

# BR 11e

## Centric Control and Shut-off Butterfly Valve

### Application:

Tight-closing, centric control and shut-off butterfly control valve with EPDM lining. Suitable for solids, liquids and gases:

- Valve sizes DN 50 to DN 1200 and NPS2 to NPS48
- Pressure rating PN10 / 16 and cl150
- Temperatures -23 to +125°C  
(depending on pressure, medium and material)

The valve consists of a EPDM-lined butterfly valve with a pneumatic rotary actuator, manual gear or ratchet lever.

The valve is designed according to the modular-assembly principle and has the following features:

- **Materials**
  - Valve body 1.0619, optionally EN-JS 1049
  - Butterfly disk 1.4408
  - Shaft 1.4122
- **Body versions**
  - Lug-type body
  - Wafer-type body
  - Double-flanged body
- **Further features**
  - Free of maintenance
  - Body able to support its own load
  - Centric mounted, streamline disk design, with special shaft connection to ensure excellent shut-off in both flow directions
  - Gaskets protruding at the sides and with additional facing to ensure a perfect seal between flanges without any additional flange gaskets
  - Shaft end and valve head design allow a wide variety of actuators to be mounted
  - Interfaces according to DIN ISO 5211
- **Fields of application**
  - Chemical and petrochemical industries
  - Water supply and wastewater industry
  - Power plant engineering, etc.

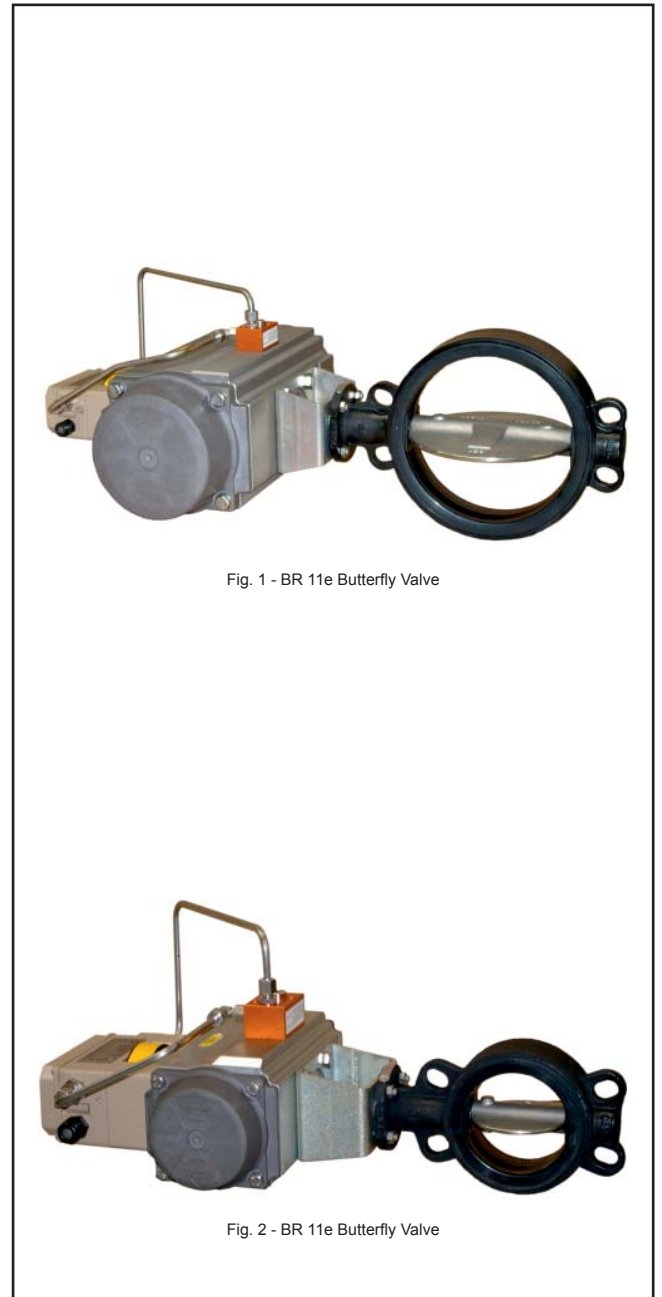

Fig. 1 - BR 11e Butterfly Valve

Fig. 2 - BR 11e Butterfly Valve

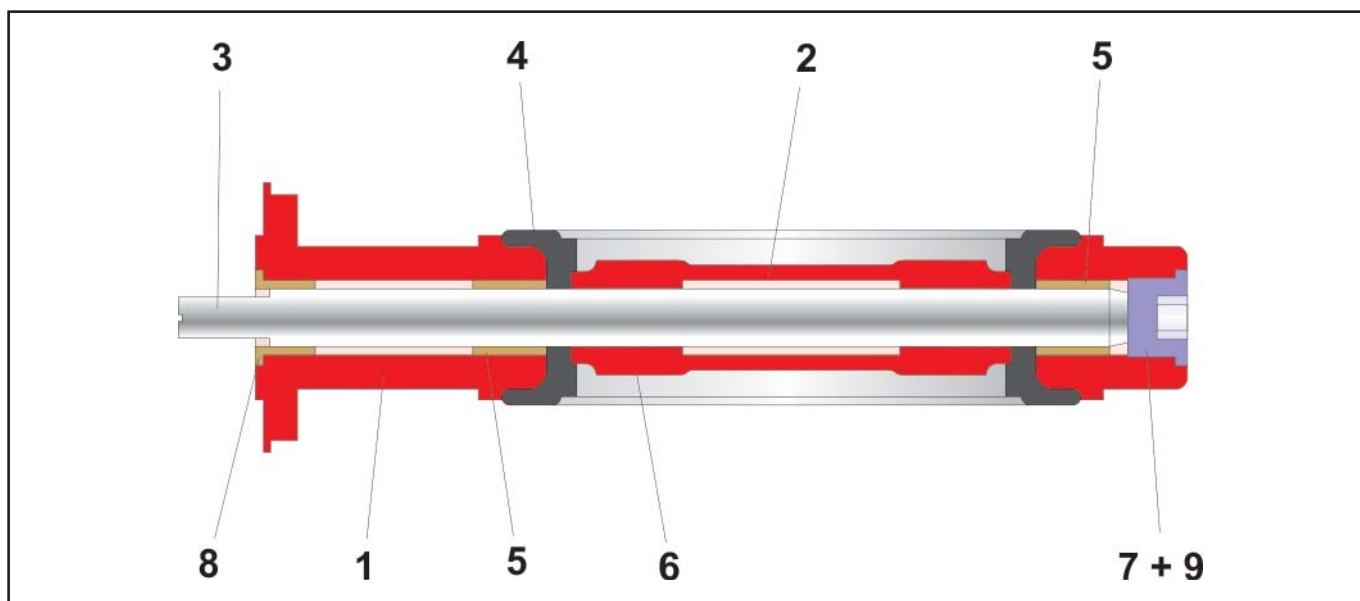

Fig. 3 - Cross-section of BR 11e Butterfly Valve

Pos.	Designation
1	Valve body
2	Butterfly disk
3	Shaft
4	Sealing ring
5	Bearing bush

Table 1 - Parts list

Pos.	Designation
6	Pin
7	Plug screw
8	Bearing bush
9	Seal

**Versions:**

Series 11e Control and Shut-off Butterfly Valve optionally available in the following versions:

- Butterfly valve with lever and ratchet
- Butterfly valve with manual gear
- Butterfly valve with BR 31a Pneumatic Rotary Actuator
- Butterfly valve with preferably with BR 30a Diaphragm Rotary Actuator

**Additional accessories and mounting parts:**

The valves are also available with accessories or in combination with the following parts:

- Pneumatic or electric actuators
- Positioners
- Limit switches
- Solenoid valves
- Supply air stations
- Pressure gauge mounting blocks

Other accessories can be mounted on request.

**Principle of operation:**

The process medium can flow through the butterfly valve in either direction.

The position of the butterfly disk ( 2 ) determines the flow rate through the free area between the disk ( 2 ) and the valve body ( 1 ).



**Fail-safe position:**

Depending on how the pneumatic rotary actuator is mounted on the valve, the valve has one of two fail-positions when the pressure on the actuator diaphragm is reduced or upon control signal failure:

**• Fail-close:**

Upon air supply failure, the butterfly valve is closed. The valve opens when the signal pressure rises opposing the force of the actuator springs.

**• Fail-open:**

Upon air supply failure, the butterfly valve is opened. The valve closes when the signal pressure rises opposing the force of the actuator springs.



**Note:** Before using the butterfly valve in hazardous areas, check whether this is possible according to 2014/34/EU (ATEX). See the mounting instructions.

**General technical data:**

	DIN	ANSI
Valve size	DN 50 to DN 1200	NPS2 to NPS48
Pressure rating	PN 10 / 16	cl150
Connection	Can mounted between flanges PN 10 / 16	Can mounted between flanges cl150
Temperature range	See pressure-temperature diagram	
Leakage rate	Leakage rate A acc. to DIN EN 12266	

Table 2 - Technical data

**Materials:**

	DIN	ANSI
Valve body	1.0619	A216 WCB
Butterfly disk	1.4408	A351 CF8M
Shaft	1.4122	
Lining	EPDM	
Bearing	1.4104	430F

Table 3 - Materials

**kvs coefficients:**

DN	NPS	$\varphi$ Opening angle									
		0°	10°	20°	30°	40°	50°	60°	70°	80°	90°
40	1½	0	0.2	0.6	2	9	22	36	56	81	110
50	2	0	0.4	0.9	3.4	14	35	57	88	126	172
65	2½	0	0.6	1.4	5.1	21	53	86	132	189	258
80	3	0	1	1.9	7.8	31	78	128	197	283	388
100	4	0	1.7	3.5	14	55	138	228	352	504	690
125	5	0	2.7	5.3	22	86	216	355	549	786	1078
150	6	0	3.9	7.8	31	124	310	512	791	1133	1552
200	8	0	6.9	14	55	221	552	918	1407	2014	2759
250	10	0	10	22	86	345	862	1422	2198	3147	4310
300	12	0	15	31	124	497	1241	2048	3166	4531	6207
350	14	0	21	42	151	676	1513	2496	3858	5522	7565
400	16	0	27	55	200	883	2004	3307	5110	7316	10022
450	18	0	35	70	256	1117	2565	4231	6540	9360	12823
500	20	0	43	86	319	1379	3194	5270	8144	11658	15970
600	24	0	62	124	466	1986	4660	7688	11881	17054	23297
700	28	0	79	157	691	2528	6321	10429	16118	23071	31605
800	32	0	96	194	774	3096	7740	12771	19737	28251	38700
900	36	0	129	259	1038	4828	10380	17127	26469	37844	51901
1000	40	0	161	324	1295	5179	12948	21365	33018	47261	64742
1200	48	0	252	506	2023	8092	20231	33383	51591	73845	101159

Table 4 - kv coefficients



**Pressure-Temperature diagram:**

The area of application is determined by the pressure-temperature diagram. Process data and the process medium can affect the values in the diagram.

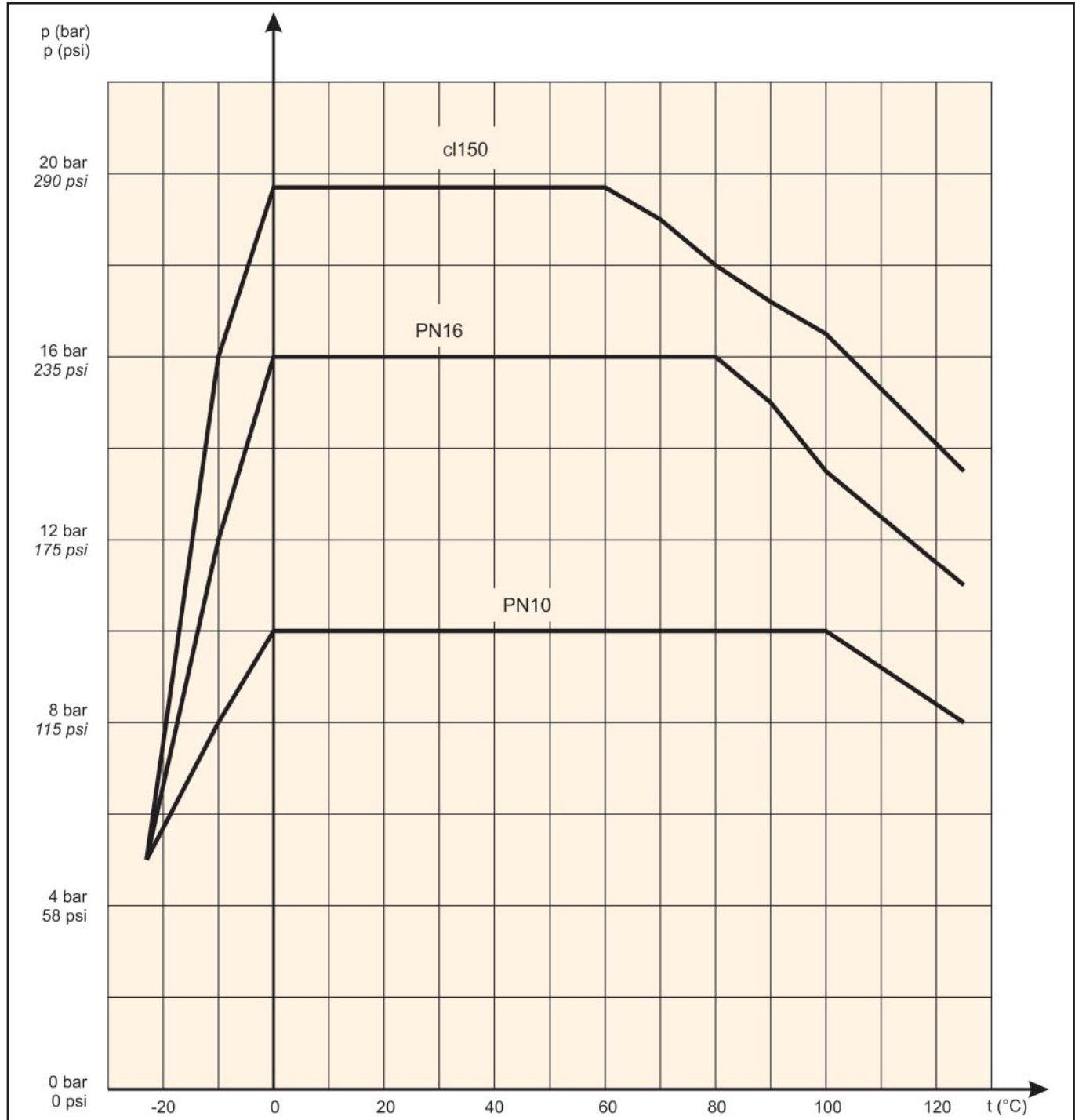

Fig. 4 - Pressure-Temperature diagram



**Note:**

Body material 1.0619/ A216 WCB: -10°C Lower operating temperature  
 Body material EN-JS 1049 (GGG 40.3): -23°C Lower operating temperature

**Torques and breakaway torques:**

DN	NPS (cl150)	Required torque Md in Nm							Mdmax. in Nm, Shaft in 1.4122
		2.5 bar	PN 10 6 bar	10 bar	2.5 bar	PN 16 / cl150 6 bar	10 bar	16 bar	
40	1½	7	8	9	7	8	9	10	101
50	2	7	8	10	7	8	10	11	101
65	2½	8	9	12	8	9	12	15	101
80	3	13	15	19	13	15	19	21	101
100	4	18	23	28	18	23	28	35	101
125	5	29	32	38	29	32	38	48	200
150	6	55	65	75	55	65	75	85	200
200	8	110	125	150	110	125	150	150	400
250	10	160	190	220	210	240	270	330	800
300	12	220	260	300	290	340	390	460	800
350	14	260	330	390	390	460	550	640	1600
400	16	460	540	640	670	760	860	1000	1600
450	18	630	750	850	750	1000	1200	1400	3200
500	20	800	900	1100	900	1200	1370	1710	3200
600	24	1330	1520	1805	2100	2280	2565	2945	6400
700 (PN10)	-	2250	2650	3050	-	-	-	-	11890
700 (PN16)	28	-	-	-	3515	3895	4250	4940	13589
800 (PN10)	-	2920	3420	3920	-	-	-	-	17749
800 (PN16)	32	-	-	-	4750	5225	5600	6500	22186
900 (PN10)	-	3880	4780	5500	-	-	-	-	22896
900 (PN16)	36	-	-	-	5600	6400	7460	8560	30886
1000 (PN10)	-	5510	6555	7695	-	-	-	-	22896
1000 (PN16)	40	-	-	-	8360	8800	9690	12350	41598
1200 (PN10)	-	9000	11420	13500	-	-	-	-	42136
1200 (PN16)	48	-	-	-	10250	12100	14700	21100	54024

Table 4 - Torques

- Specified breakaway torques apply to liquids and lubricating media
- Dry, powdery media:  $Md_{los} \times 1.25$

**Functional diagram with opening angles:**

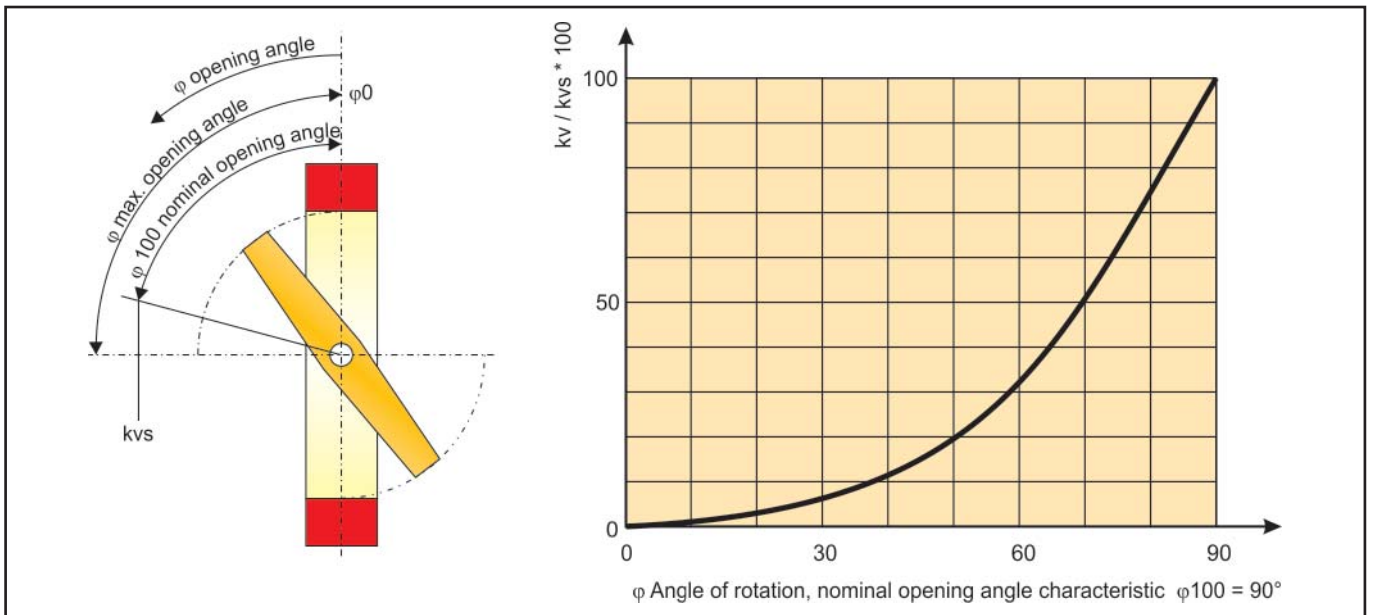

Fig. 5 - Functional diagram with opening angles

### Lug-Type Butterfly valves Part 1

Dimensions and weights DN 40 to DN 200 and NPS1½ to NPS8

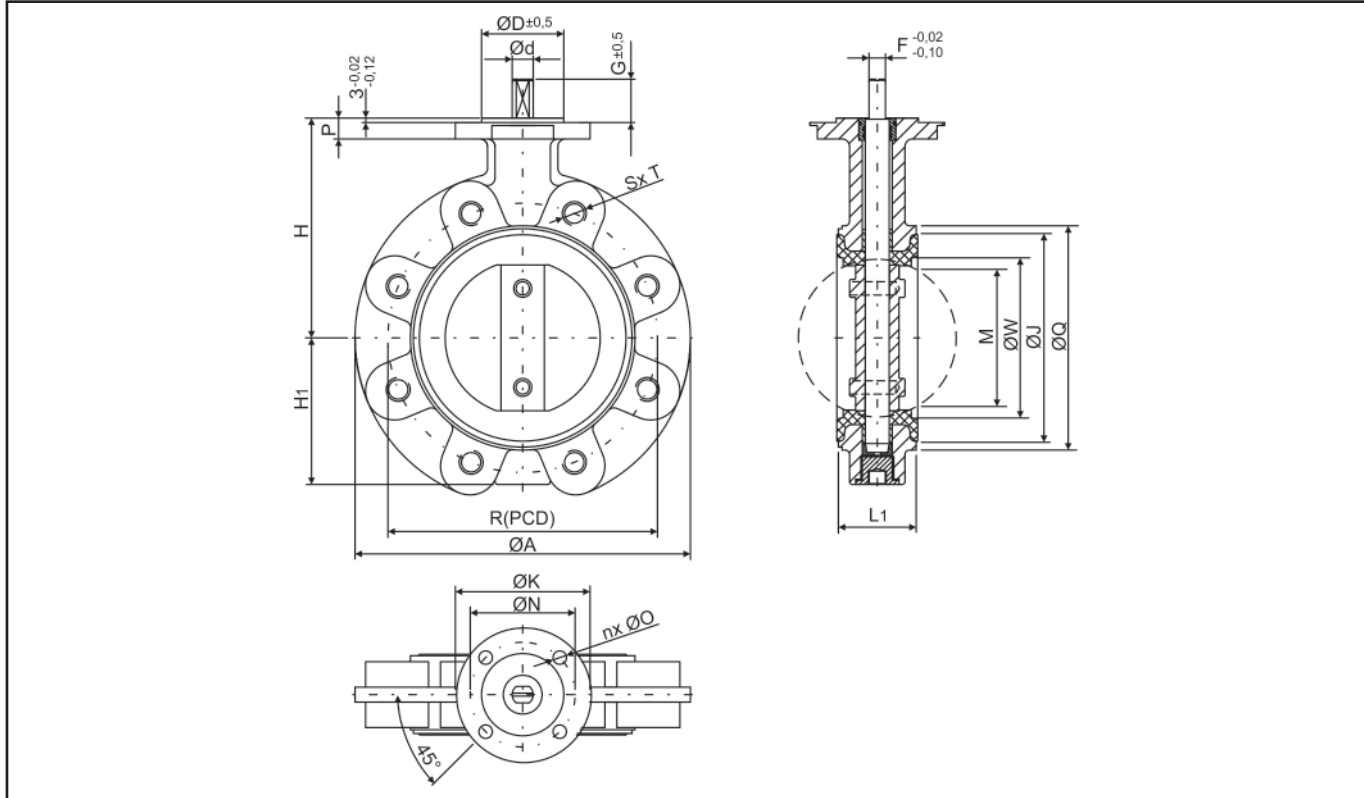

Fig. 6 - Lug-type valves DN 40 to DN 200 and NPS1½ to NPS8

DN	40	50	65	80	100	125	150	200
NPS	1½	2	2½	3	4	5	6	8
ØA	150	165	185	195	224	254	285	337
F	11	11	11	11	11	14	14	17
G	28	28	28	28	28	31	31	31
Ød	14	14	14	14	16	18	20	22
ØD	55	55	55	55	55	55	55	55
H	113	118	126	133	147	160	180	204
H <sub>i</sub>	56	67	74	82	100	112	134	159
ØK	90	90	90	90	90	90	90	90
L <sub>1</sub>	33	43	46	46	52	56	56	60
ØN	70	70	70	70	70	70	70	70
DIN ISO	F07	F07	F07	F07	F07	F07	F07	F07
nx ØO	4x 9	4x 9	4x 9	4x 9	4x 9	4x 9	4x 9	4x 9
P	12	12	12	14	14	14	14	14
R (pcd)	PN10							
	PN16	110	125	145	160	180	210	295
	cl150	98.4	120.7	139.7	152.4	190.5	215.9	298.5
Sx T	PN10	4x M16	4x M16	4xM16	8x M16	8x M16	8x M16	8x M20
	PN16							8x M20
	cl150	4x ½"UNC	4x ¾"UNC	4x ¾"UNC	4x ¾"UNC	8x ¾"UNC	8x ¾"UNC	8x ¾"UNC
M	22.6	29.8	49.4	68.2	89.6	113.9	140	192
ØW	42.5	54.5	69.8	84.4	105.6	130.4	154	205.4
ØJ	61	78	91	112	138	170	194	248
ØQ	72	90	105	124	150	182	210	265
Weight	PN10						15	19
	PN16 / cl150	3.4	4	5.2	6.5	8.3	9	14

Table 6 - Dimensions in mm and weights in kg of the Lug type valves DN 40 to DN 200 and NPS1½ to NPS8

## Lug-Type Butterfly valves Part 2

Dimensions and weights DN 250 to DN 600 and NPS10 to NPS24

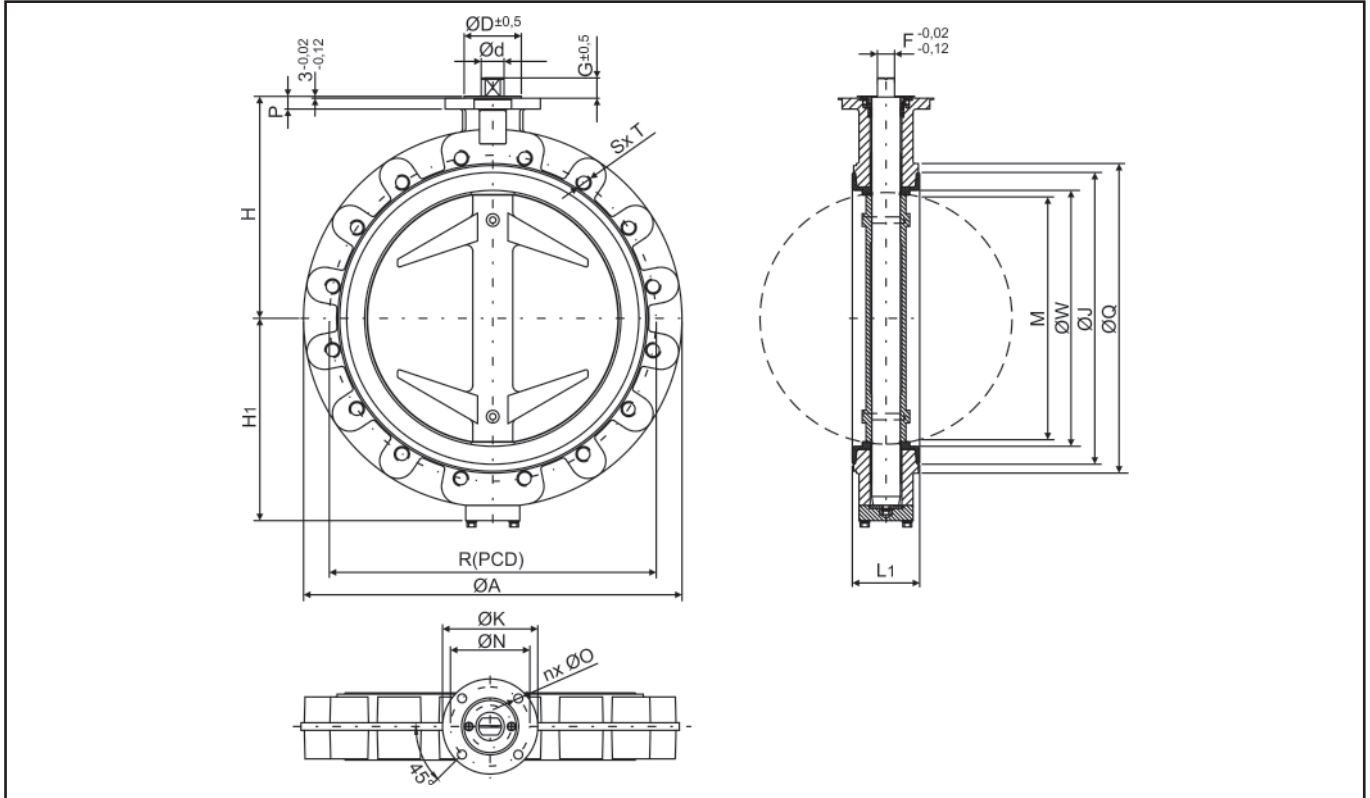

Fig. 7 - Lug-type valves DN 250 to DN 600 and NPS10 to NPS24

DN	250	300	350	400	450	500	600	
NPS	10	12	14	16	18	20	24	
ØA	PN10	405	472	520	596	640	710	780
	PN16			533		635		840
	cl150							
F	22	22	27	27	36	36	46	
G	33	33	32	32	41	41	51	
Ød	30	35	40	45	50	60	70	
ØD	70	70	85	85	100	100	130	
H	245	270	315	350	375	415	465	
H1	195	220	294	319	352	387	452	
ØK	125	125	150	150	175	175	210	
L1	68	78	78	102	114	127	154	
ØN	102	102	125	125	140	140	165	
DIN ISO	F10	F10	F12	F12	F14	F14	F16	
nx ØO	4x 11	4x 11	4x 14	4x 14	4x 18	4x 18	4x 22	
P	15	15	20	20	20	20	25	
R (pcd)	PN10	350	400	460	515	565	620	725
	PN16	355	410	470	525	585	650	770
	cl150	362	431.8	476.3	539.8	577.9	635	749.3
Sx T	PN10	12x M20	12x M20	16x M20	16x M24	20x M24	20x M24	20x M27
	PN16	12x M24	12x M24	16x M24	16x M27	20x M27	20x M30	20x M33
	cl150	12x 1/8"UNC	12x 3/8"UNC	12x 1"UNC	16x 1"UNC	16x 1 1/8"8UN	20x 1 1/8"8UN	20x 1 1/4"8UN
M	243	294	327.5	382.8	432.2	481	581	
ØW	256.7	310.1	341.5	403	449.2	499.2	603	
ØJ	299	353	405	460	517	570	670	
ØQ	315	371	434	488	540	590	692	
Weight	PN10	35	51	63	89	114	165	197
	PN16 / cl150	37	54	66	94	120	173	234

Table 7 - Dimensions in mm and weights in kg of the Lug type valves DN 250 to DN 600 and NPS10 to NPS24

### Lug-Type Butterfly valves Part 3

Dimensions and weights DN 700 to DN 1200 and NPS28 to NPS48

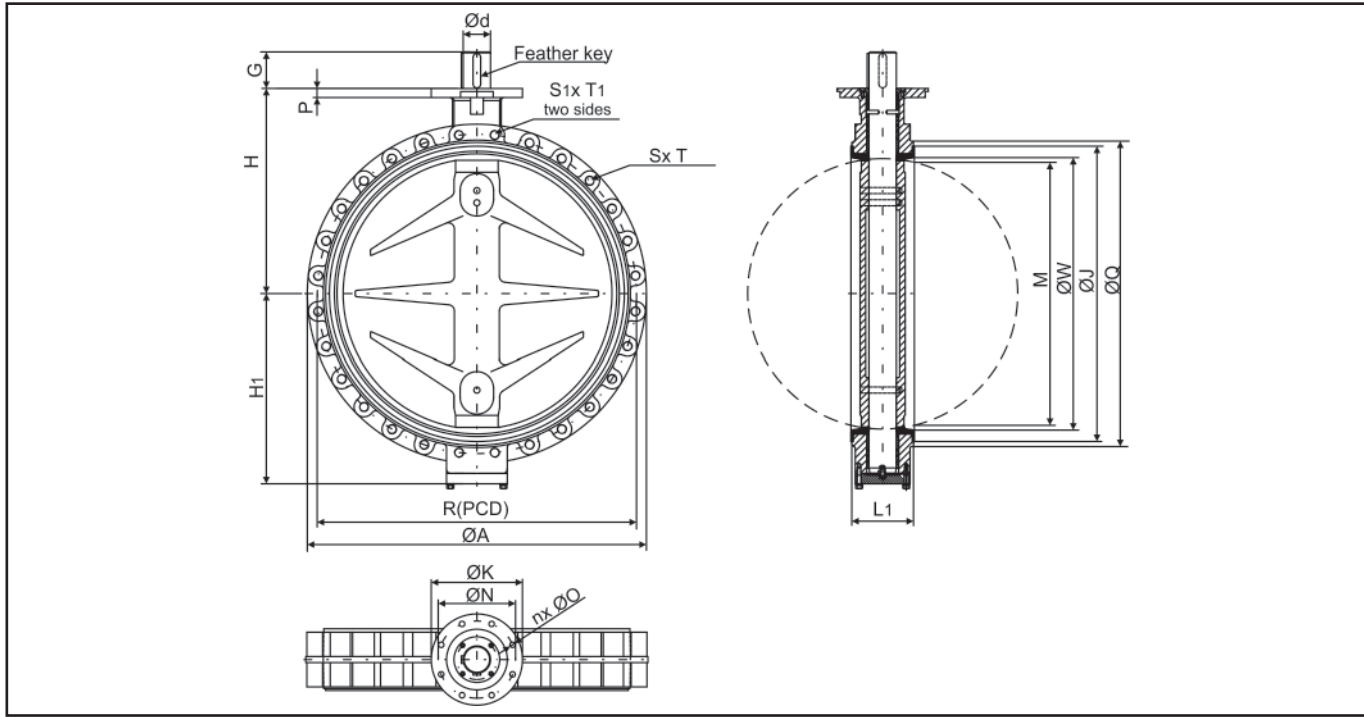

Fig. 8 - Lug-type valves DN 700 to DN 1200 and NPS28 to NPS48

DN	700	800	900	1000	1200
NPS	28	32	36	40	48
ØA	PN10	1015	1115	1230	1455
	PN16	1025	1125	1255	1485
	cl150	1050	1168	1289	1511
G	PN10	120	120	120	160
	PN16 / cl150	120	160	160	160
Ød	PN10	80	90	90	110
	PN16 / cl150	80	100	110	130
Feather key	2x 22x110	2x 28x110	2x 28x140	2x 32x140	2x 32x140
H	555	620	675	740	875
H <sub>1</sub>	489	549	624	674	802
ØK	PN10	210	300	300	350
	PN16 / cl150	300	300	300	350
L <sub>1</sub>	PN10	165	190	203	216
	PN16 / cl150	165	254	254	254
DIN ISO	PN10	F16	F25	F25	F25
	PN16 / cl150	F25	F25	F25	F30
nx ØQ	PN10	4x 22	8x 18	8x 18	8x 18
	PN16 / cl150	8x 18	8x 18	8x 18	8x 22
P	PN10	25	30	30	40
	PN16 / cl150	35	30	30	40
R (pcd)	PN10	840	950	1050	1160
	PN16	840	950	1050	1170
	cl150	863.6	977.9	1086	1200
Sx T	PN10	20x M27	20x M30x45	24x M30x45	24x M33x50
	PN16	20x M33	20x M36x54	24x M36x54	24x M39x60
	cl150	24x 1 1/4"8UN	24x 1 1/2"8UNx58	28x 1 1/2"8UNx57	32x 1 1/2"8UNx57
S1x T1	PN10	4x M27x37x30	4x M30x40x30	4x M30x45x35	4x M33x55x45
	PN16	4x M33x37x30	4x M36x36x30	4x M30x35x26	4x M39x37x28
	cl150	4x 1 1/4"8UNx32x24	4x 1 1/2"8UNx31x26	4x 1 1/2"8UNx35x28	4x 1 1/2"8UNx31x25
M	667	765	864	961	1145
ØW	695	794	895	990	1186
ØJ	772	873	970	1070	1285
ØQ	PN10	800	910	1003	1110
	PN16 / cl150	805	910	1003	1110
Weight	PN10	375	630	700	970
	PN16	405	670	758	1020
	cl150	436	704	843	1116

Table 8 - Dimensions in mm and weights in kg of the Lug type valves DN 700 to DN 120 and NPS28 to NPS48



### Wafer-Type Butterfly valves Part 1

Dimensions and weights DN 40 to DN 200 and NPS1½ to NPS8

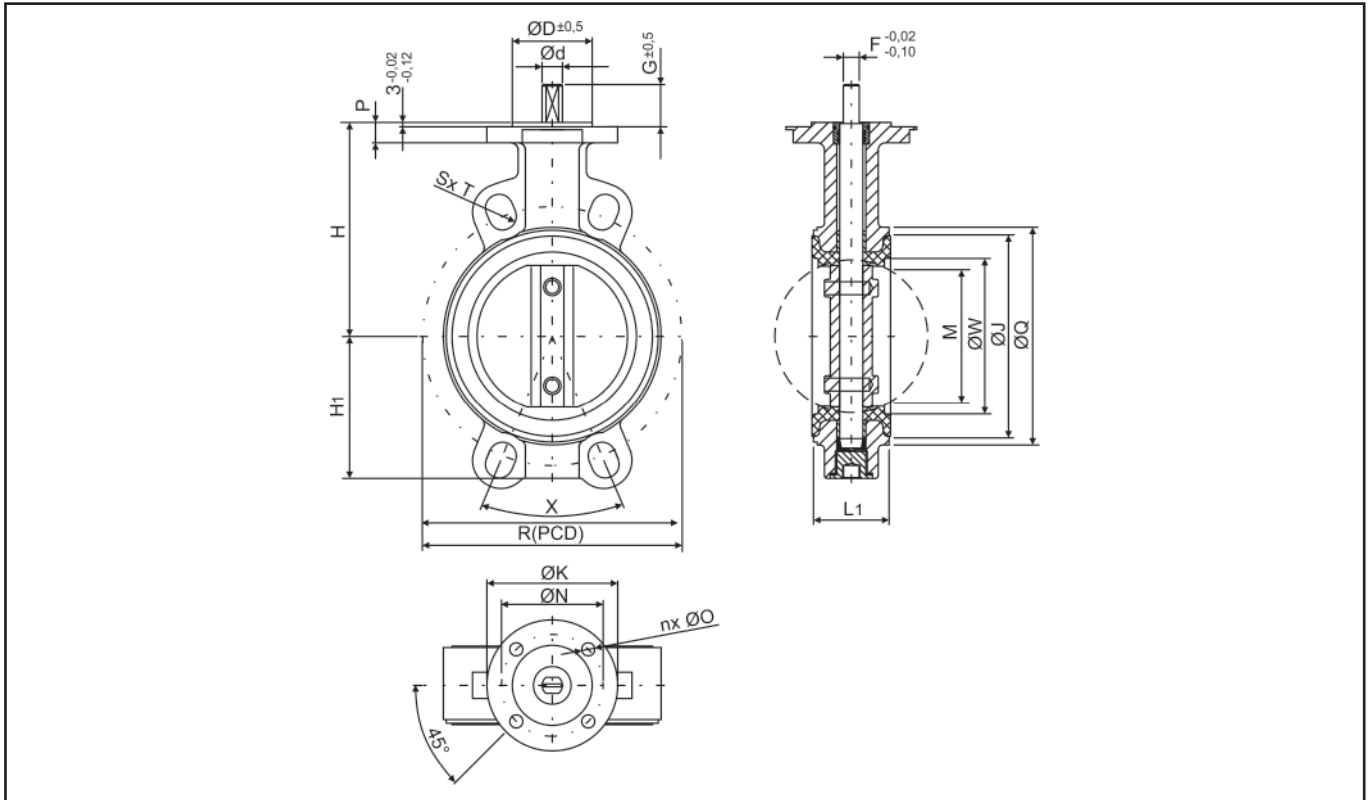

Fig. 9 - Wafer-type valves DN 40 to DN 200 and NPS1½ to NPS8

DN	40	50	65	80	100	125	150	200	
NPS	1½	2	2½	3	4	5	6	8	
F	11	11	11	11	11	14	14	17	
G	28	28	28	28	28	31	31	31	
Ød	14	14	14	14	16	18	20	22	
ØD	55	55	55	55	55	55	55	55	
H	113	118	126	133	147	160	180	204	
H1	56	67	74	82	100	112	134	159	
ØK	90	90	90	90	90	90	90	90	
L1	33	43	46	46	52	56	56	60	
ØN	70	70	70	70	70	70	70	70	
DIN ISO	F07	F07	F07	F07	F07	F07	F07	F07	
nx ØO	4x 9	4x 9	4x 9	4x 9	4x 9	4x 9	4x 9	4x 9	
P	12	12	12	14	14	14	14	14	
R (pcd)	PN10 / PN16	110	125	145	160	180	210	240	295
	cl150	98.4	120.7	139.7	152.4	190.5	215.9	241.3	298.5
Sx T	PN10 / PN16	4x R9	4x R9	4x R9	4x R9	4x R9	4x R9	4x R11	4x R11
	cl150	4x R8	4x R9.5	4x R9.5	4x R9.5	4x R9.5	4x R11		
X	PN10 / PN16	90°	90°	90°	45°	45°	45°	45°	45°
	cl150				90°				30°
M	22.6	29.8	49.4	68.2	89.6	113.9	140	192	
ØW	42.5	54.5	69.8	84.4	105.6	130.4	154	205.4	
ØJ	61	78	91	112	138	170	194	248	
ØQ	72	90	105	124	150	182	210	265	
Weight	2.6	3.2	3.4	4.3	5.2	7.3	9.3	14	

Table 9 - Dimensions in mm and weights in kg of the Wafer-type valve DN 40 to DN 200 and NPS1½ to NPS8

## Wafer-Type Butterfly valves Part 2

Dimensions and weights DN 250 to DN 600 and NPS10 to NPS24

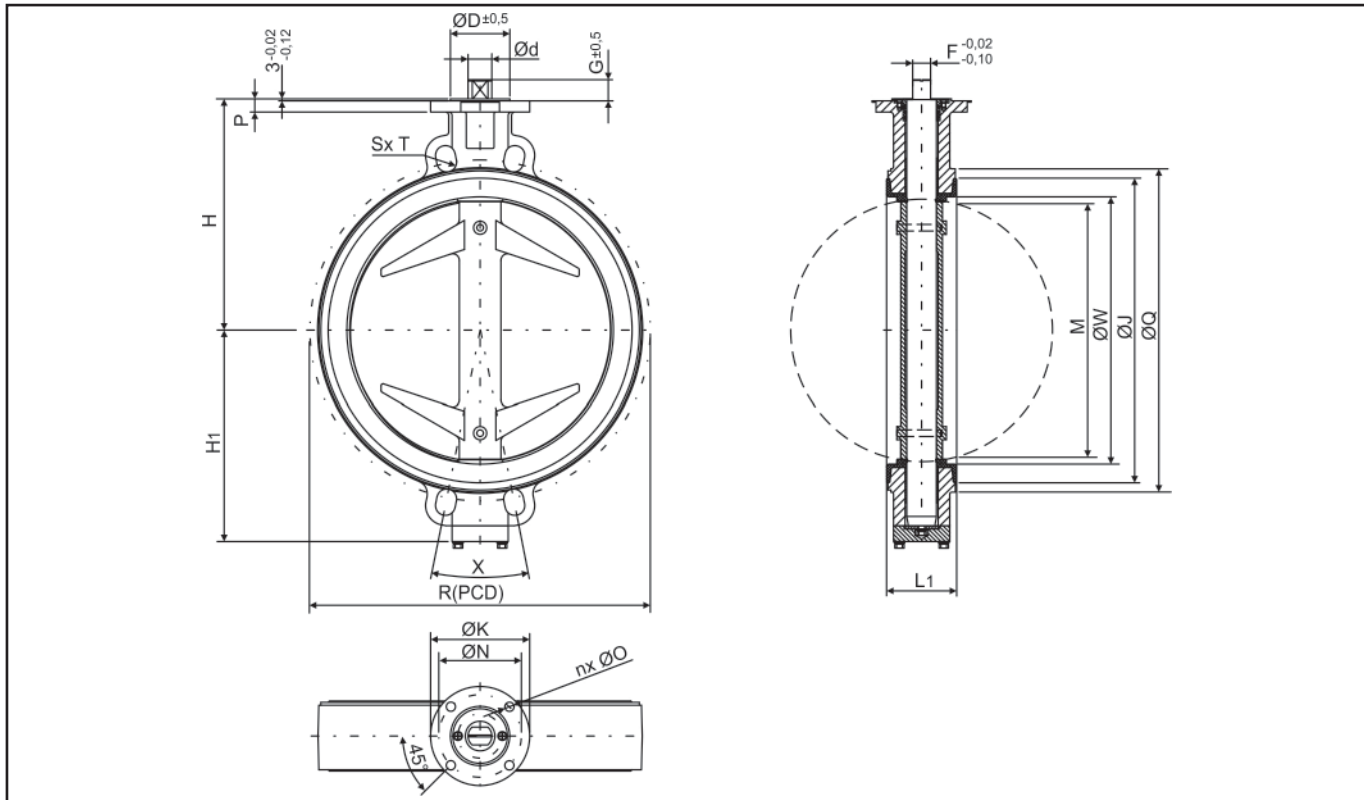

Fig. 10 - Wafer-type valves DN 250 to DN 600 and NPS10 to NPS24

DN	250	300	350	400	450	500	600
NPS	10	12	14	16	18	20	24
F	22	22	27	27	36	36	46
G	33	33	32	32	41	41	51
$\text{Ød}$	30	35	40	45	50	60	70
$\text{ØD}$	70	70	85	85	100	100	130
H	245	270	315	350	375	415	465
$H_1$	195	220	294	319	352	387	452
$\text{ØK}$	125	125	150	150	175	175	210
$L_1$	68	78	78	102	114	127	154
$\text{ØN}$	102	102	125	125	140	140	165
DIN ISO	F10	F10	F12	F12	F14	F14	F16
$nx \text{ØØ}$	4x 11	4x 11	4x 14	4x 14	4x 18	4x 18	4x 22
P	15	15	20	20	20	20	25
R (pcd)	PN10	350	400	460	515	565	725
	PN16	355	410	470	525	585	770
	cl150	362	431.8	476.3	539.8	577.9	749.3
Sx T	PN10	4x R11	4x R11	4x R11	4x R13	4x M24	4x M24
	PN16	4x R13	4x R13	4x R13	4x R15	4x M27	4x M30
	cl150	4x R12.5	4x R12.5	4x R14.5	4x R14.5	4x 1 1/8"8UN	4x 1 1/4"8UN
X	PN10		22.5°	22.5°		18°	
	PN16 / cl150	30°	30°	30°	22.5°	22.5°	18°
M	243	294	326.5	383	432.2	481	581
$\text{ØW}$	256.7	310.1	341.5	403	449.2	499.2	603
$\text{ØJ}$	299	353	405	460	517	570	670
$\text{ØQ}$	315	371	434	488	540	590	692
Weight	PN10	20	31	48	71	99	205
	PN16 / cl150	21	32	49	73	102	210

Table 10 - Dimensions in mm and weights in kg of the Wafer-type valve DN 250 to DN 600 and NPS10 to NPS24

### Wafer-Type Butterfly valves Part 3

Dimensions and weights DN 700 to DN 1200 and NPS28 to NPS48

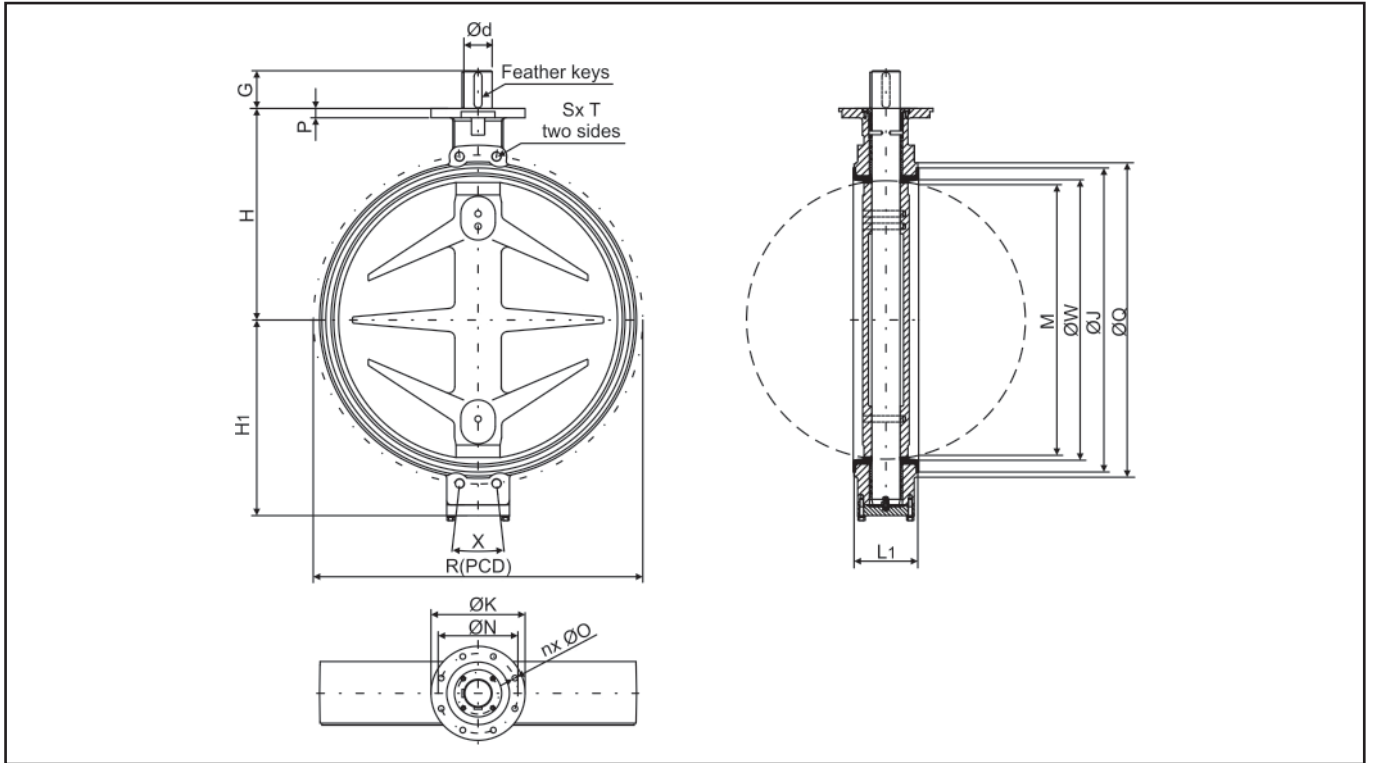

Fig. 11- Wafer-type valves DN 700 to DN 1200 and NPS28 to NPS48

		700	800	900	1000	1200
DN		700	800	900	1000	1200
NPS		28	32	36	40	48
G	PN10	110		120	120	
	PN16 / cl150	120	120	160	160	160
Ød	PN10	70	80	90	90	110
	PN16 / cl150	80	100	110	120	130
Feather key		2x 22x110	2x 28x110	2x 28x140	2x 32x140	2x 32x140
H		555	620	675	740	875
H <sub>1</sub>		489	549	624	674	802
ØK	PN10	210		300		
	PN16 / cl150	300	300	300	300	350
L <sub>1</sub>	PN10	165		203		
	PN16 / cl150	254	254	254	254	298
DIN ISO	PN10	F16		F25		
	PN16 / cl150	F25	F25	F25	F25	F30
nx ØO	PN10	4x 22		8x 18		
	PN16 / cl150	8x18	8x 18	8x 18	8x 18	8x 22
P	PN10	25		30		
	PN16 / cl150	35	30	30	30	40
R (pcd)	PN10				1160	1380
	PN16	840	950	1050	1170	1390
	cl150	863.6	977.9	1086	1200	1422
Sx T	PN10	4x M27x37x30	4x M30x40x30	4x M30x45x35	4x M33x55x45	4x M36x55x45
	PN16	4x M33x37x30	4x M36x36x30	4x M30x35x26	4x M39x37x28	4x M45x50x40
	cl150	4x1½"8UNx32x24	4x1½"8UNx31x26	4x1½"8UNx35x28	4x1½"8UNx31x25	4x1½"8UNx43x33
X	PN10	18°				
	PN16	15°	15°	12.86°	12.86°	11.25°
	cl150	12.86°	12.86°	11.25°	10°	8.18°
M		667	765	864	961	1145
ØW		695	794	895	990	1186
ØJ		772	873	970	1070	1285
ØQ		800	910	1003	1110	1325
Weight	PN10	320	350	500	750	1250
	PN16	340	382	540	798	1302
	cl150	375	420	589	877	1380

Table 11 - Dimensions in mm and weights in kg of the Wafer-type valve DN 700 to DN 1200 and NPS28 to NPS48

## Double-flanged Butterfly valves Part 1

Dimensions and Weights DN 50 to DN 200 and NPS2 to NPS8

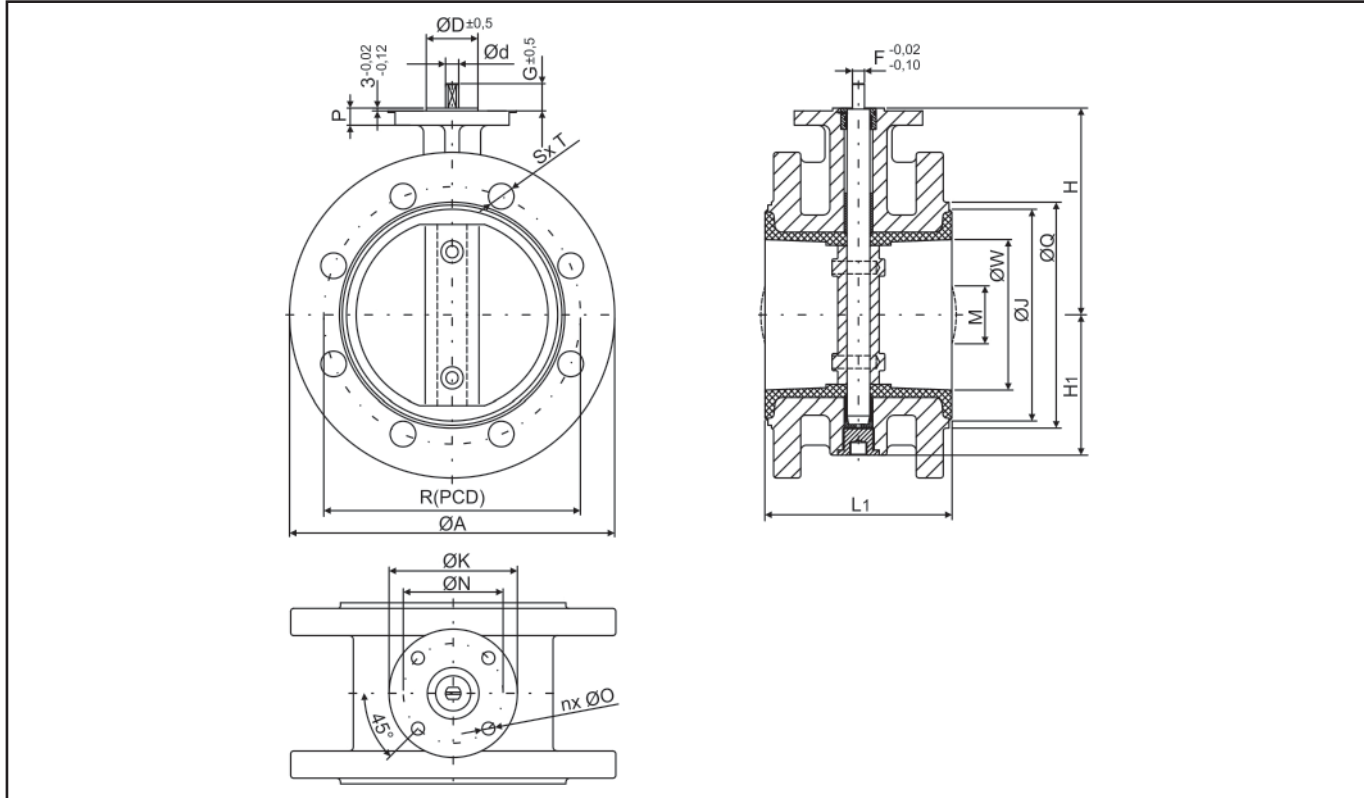

Fig. 12 - Double-flanged valve DN 50 to DN 200 and NPS2 to NPS8

DN	50	65	80	100	125	150	200	
NPS	2	2½	3	4	5	6	8	
ØA	PN10 / PN16	165	185	200	220	250	285	340
	cl150	150	180	190	228	255	280	343
F	11	11	11	11	14	14	17	
G	28	28	28	28	31	31	31	
Ød	14	14	14	16	18	20	22	
ØD	55	55	55	55	55	55	55	
H	118	126	133	147	160	180	204	
H <sub>1</sub>	67	74	82	100	112	134	159	
ØK	90	90	90	90	90	90	90	
L <sub>1</sub>	108	112	114	127	140	140	152	
ØN	70	70	70	70	70	70	70	
DIN ISO	F07	F07	F07	F07	F07	F07	F07	
n x ØO	4x 9	4x 9	4x 9	4x 9	4x 9	4x 9	4x 9	
P	12	12	14	14	14	14	14	
R (pcd)	PN10	125	145	160	180	210	240	295
	PN16							
	cl150	120.7	139.7	152.4	190.5	215.9	241.3	298.5
S x ØT	PN10	4x 18	4x 18	8x 18	8x 18	8x 18	8x 22	8x 22
	PN16						8x 22	12x 22
	cl150	4x 19	4x 19	4x 19	8x 19	8x 22		8x 22
M	-	-	-	-	-	45	128	
ØW	55	70	86	108	130.4	154.4	205.4	
ØJ	85	100	118	144	173	202	255	
ØQ	104	122	130	158	191	215	268	
Weight	7	9	10	14	17	21	32	

Table 12 - Dimensions in mm and Weights in kg of the Double-flanged valves DN 50 to DN 200 and NPS2 to NPS8

## Double-flanged Butterfly valves Part 2

Dimensions and Weights DN 250 to DN 600 and NPS10 to NPS24

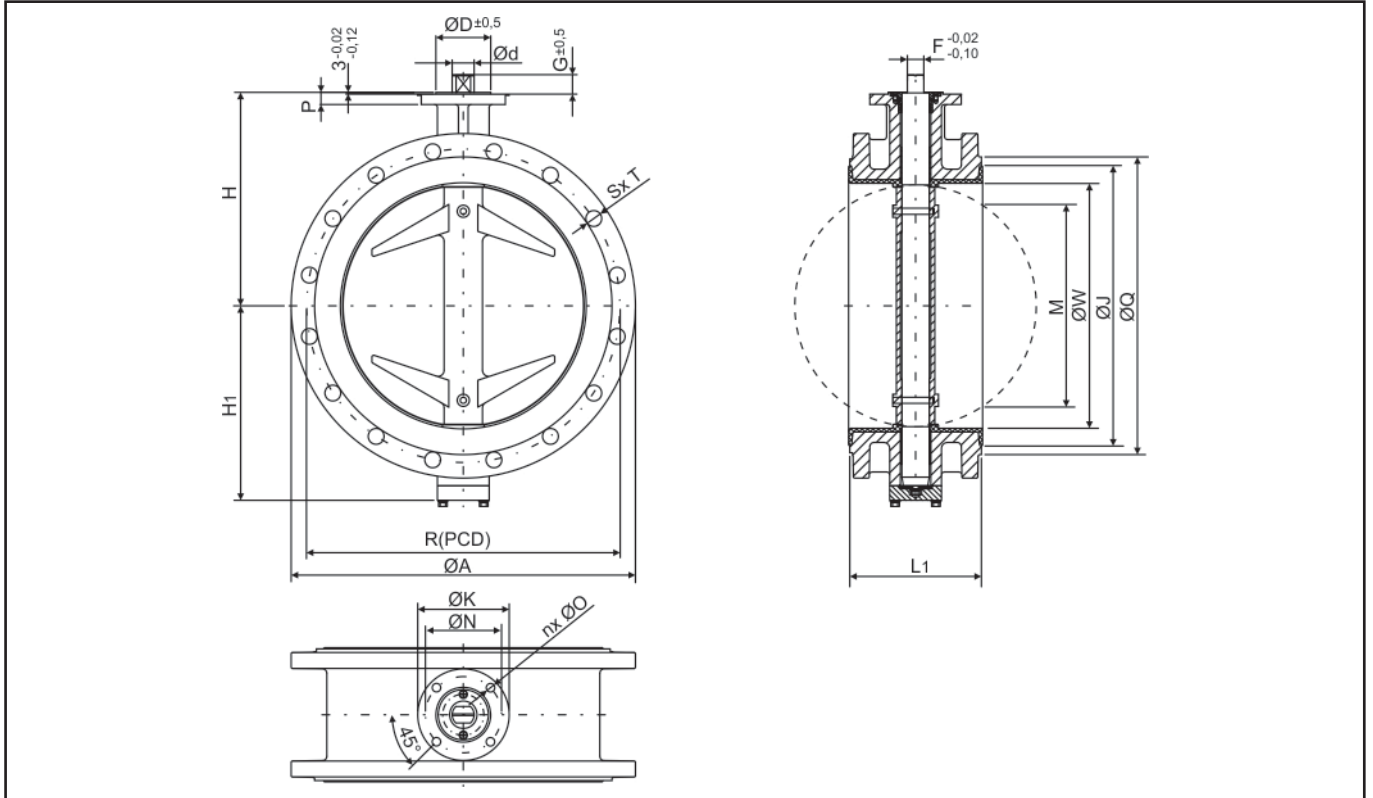

Fig. 13 - Double-flanged valve DN 250 to DN 600 and NPS10 to NPS24

DN	250	300	350	400	450	500	600
NPS	10	12	14	16	18	20	24
$\varnothing A$	PN10	395	445	505	565	615	780
	PN16		460	520	580	640	840
	cl150	405	482	533	595	635	815
F	22	22	27	27	36	36	46
G	33	33	32	32	41	41	51
$\varnothing d$	30	35	40	45	50	60	70
$\varnothing D$	70	70	85	85	100	100	130
H	245	270	315	350	375	415	465
$H_1$	195	220	294	319	352	387	452
$\varnothing K$	125	125	150	150	175	175	210
$L_1$	165	178	190	216	222	229	267
$\varnothing N$	102	102	125	125	140	140	165
DIN ISO	F10	F10	F12	F12	F14	F14	F16
$nx \varnothing O$	4x 11	4x 11	4x 14	4x 14	4x 18	4x 18	4x 22
P	15	15	20	20	20	20	25
R (pcd)	PN10	350	400	460	515	565	725
	PN16	355	410	470	525	585	770
	cl150	362	431.8	476.3	539.8	577.9	749.3
Sx T	PN10	12x 22	12x 22	16x 22	16x 26	20x 26	20x 30
	PN16	12x 26	12x 26	16x 26	16x 30	20x 30	20x 36
	cl150	12x 25	12x 25	12x 29	16x 29	16x 32	20x 35
M	187.5	243.5	277	332.5	388.5	442	538.5
$\varnothing W$	258.4	312	351	403	449.2	499.2	604.2
$\varnothing J$	310	360	405	460	517	570	670
$\varnothing Q$	324	374	438	488	536	590	692
Weight	PN10	47	51	80	101	132	231
	PN16 / cl150		69	95	121	150	291

Table 13 - Dimensions in mm and Weights in kg of the Double-flanged valves DN 250 to DN 600 and NPS10 to NPS24

### Double-flanged Butterfly valves Part 3

Dimensions and Weights DN 700 to DN 1200 and NPS28 to NPS48

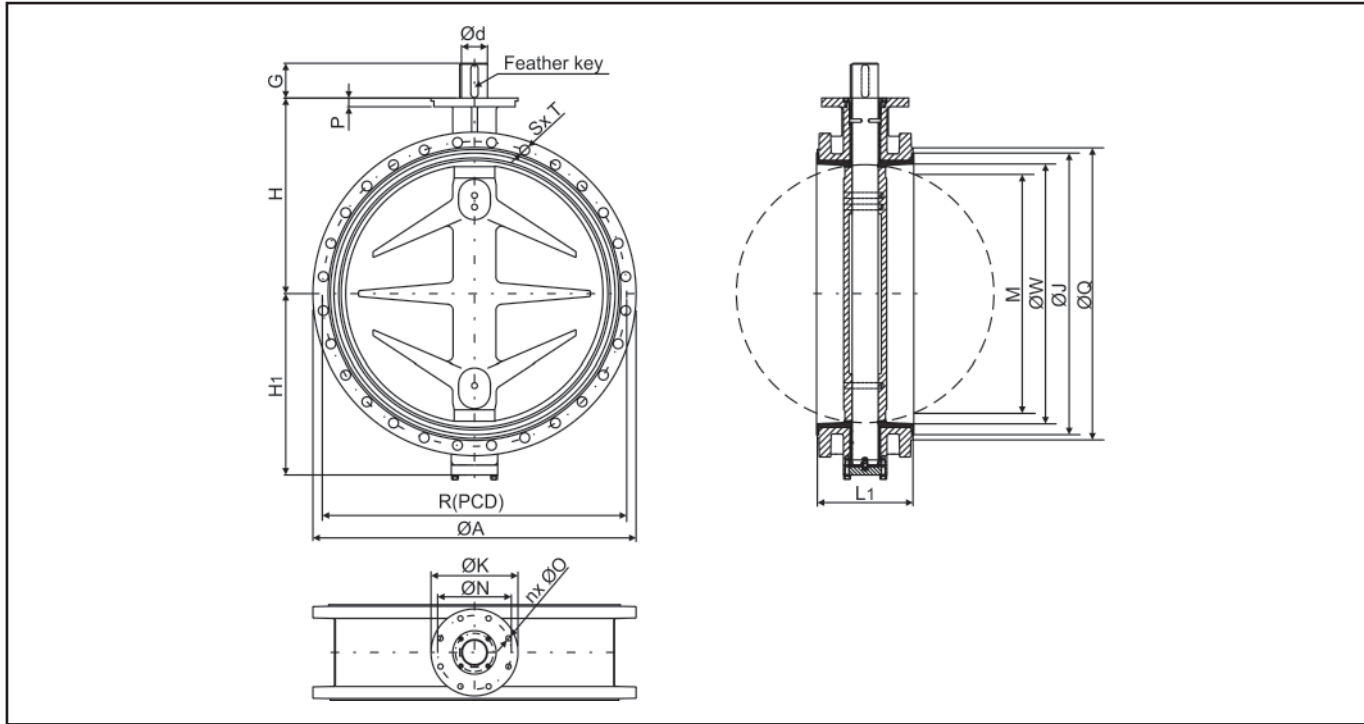

Fig. 14 - Double-flanged valve DN 700 to DN 1200 and NPS28 to NPS48

DN	700	800	900	1000	1200
NPS	28	32	36	40	48
ØA	PN10	895	1015	1115	1230
	PN16	910	1025	1125	1255
	cl150	925	1060	1168	1290
G	PN10	110	120	120	160
	PN16 / cl150	120	120	160	160
Ød	PN10	70	80	90	110
	PN16 / cl150	80	100	110	120
Feather key	PN10	2x 20x110	2x 22x110	2x 25x110	2x 25x110
	PN16 / cl150	2x 22x110	2x 28x110	2x 28x140	2x 32x140
H	PN10	555	620	675	875
	PN16 / cl150	489	549	614	664
H1	PN10	210	300	300	350
	PN16 / cl150	300	300	300	300
ØK	PN10	292	318	330	410
	PN16 / cl150	165	254	254	254
L1	PN10	165	254	254	254
	PN16 / cl150	254	254	254	254
DIN ISO	PN10	F16	F25	F25	F25
	PN16 / cl150	F25	F25	F25	F25
nx ØO	PN10	4x 22	8x 18	8x 18	8x 18
	PN16 / cl150	8x 18	8x 18	8x 18	8x 22
P	PN10	25	30	30	40
	PN16 / cl150	35	30	30	40
R (pcd)	PN10	840	950	1050	1160
	PN16	840	950	1050	1170
	cl150	863.6	977.9	1086	1200
Sx T	PN10	24x 30	24x 33	28x 33	28x 36
	PN16	24x 36	20x 39	24x 39	28x 42
	cl150	24x 35	24x 41	28x 41	32x 41
S1x T1	PN16	-	4x M36	4x M36	-
	cl150	4x1¼"8UNx60x48	4x1½"8UNx76x63	4x1½"8UNx50x40	4x1½"8UNx67x57
M	621.5	721	823.5	894.5	1073.5
ØW	695	794	895	990	1186
ØJ	772	874	970	1070	1285
ØQ	804	905	1006	1108	1325
Weight	PN10	365	440	671	990
	PN16	415	490	722	1048
	cl150	436	684	969	1332

Table 14 - Dimensions in mm and Weights in kg of the Double-flanged valves DN 700 to DN 1200 and NPS28 to NPS48



**Selecting and sizing the butterfly valve:**

1. Calculate the appropriate  $K_{VS}$  coefficient.
2. Select the valve size and the  $K_{VS}$  coefficient from Table 5.
3. Select a suitable actuator.



**Note:** All relevant details regarding the version ordered, which deviate from the specified version in this technical description, can be taken if required, from the corresponding order confirmation.

**Ordering text:**

BR 11e Control and Shut-off Butterfly Valve

DN . . . .

PN . . . .

optional special version

Actuator (brand name): . . . .

Signal pressure: . . . . bar

Fail-safe action: . . . .

Limit switch (brand name): . . . .

Solenoid valve (brand name): . . . .

Positioner: . . . .

Others: . . . .

